

Assembly Instructions

MODEL

CG-CH-4401-RUS-RTA
 CG-CH-4401-CHY-RTA
 CG-CH-4401-DRK-RTA
 CG-CH-4501-RUS-RTA
 CG-CH-4501-DRK-RTA
 CG-CH-4501-LGT-RTA
 CG-CH-4505-RST-RTA

Thank you for purchasing this quality product. Carefully check all packing material for small parts which may have come loose inside the carton during shipment. Keep all hardware out of the reach of small children. Study all the instructions and drawings carefully before assembly. Check that all connections are tight and the product does not wobble before using.

NOTE:
PLEASE FOLLOW THE ASSEMBLY INSTRUCTION BASE ON WHAT MODEL THAT YOU PURCHASED.
HARDWARE QUANTITY IS FOR ONE PIECE OF CHAIR.

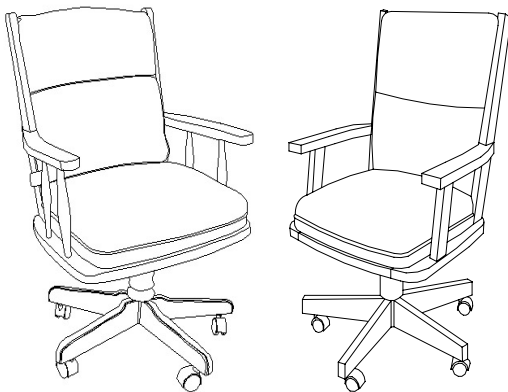

PARTS CHECKLIST

ITEM	PART NAME	QTY
A	WOOD ARMS	2
B	WOOD COLUMN	1
C	BASE PLATE	1
D	CASTOR	5

HARDWARE CHECK LIST

ITEM	PART NAME	QTY
E	BOLT 1/4"*2-3/4" 	2
F	FLAT WASHER d 7/16" 	2
G	LOCK WASHER d 7/16" 	6
H	SCREW 	2
I	FLAT WASHER d 1-1/4" 	2
J	BOLT 1/4"*1" 	4
K	FLAT WASHER d 3/4" 	4
L	ALLEN WRENCH 	1
M	Wood cap 	2

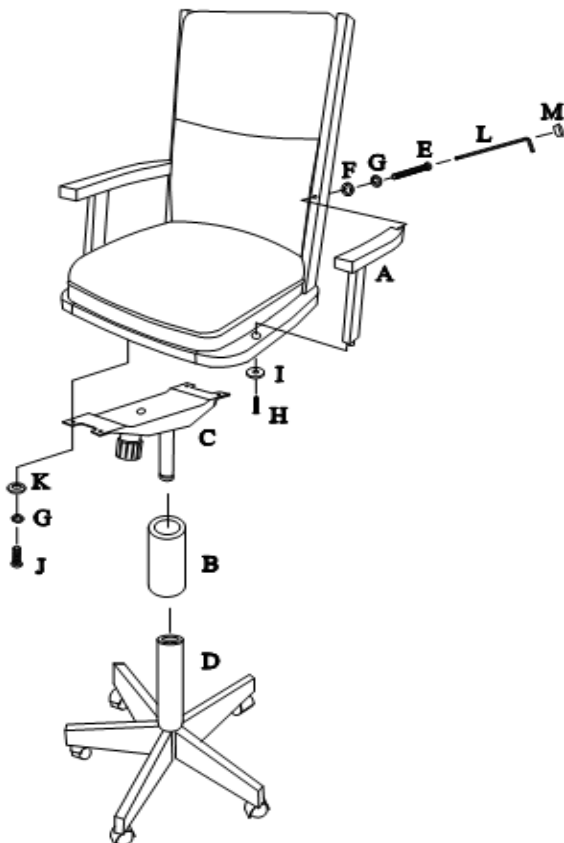

Step 1: Attach the arm post to the seat frame by using 2 Screws (H) and 2 Flat Washers(I) with wrench(L) provided. Attach the end of the arms to the chair back by using 2 Long Bolts(E), 2 Flat Washers(F) and 2 Lock Washers(G) with wrench(L) provided.

Step 2: Insert the castors into the base frame.

Step 3: Turn over the top of the chair and secure the base plate to the seat frame with 4 Bolts(J), 4 Flat Washers(K) and 4 Lock Washers(G) with Wrench(L) provided.

Step 4: Slide the wood column(B) over the metal tube(D), and then insert the cylinder of the plate into the chair base.

Step 5: Tighten all bolts firmly to make sure all connections are tight and the chair does not wobble before using.

Step 6: Cover the screw holes on the chair back with 2 Wood Plugs(M).