

ASSEMBLY INSTRUCTION

For Model :

AR - BS - 185 - BLJ - K24

AR - BS - 185 - JAV - K24

AR - BS - 185 - WHJ - K24

Description : 24" Lattice Back Barstool

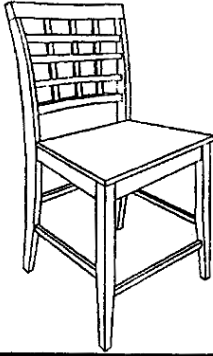

IMPORTANT NOTE :

- Place all wooden parts on a clean and smooth surface such as a rug or carpet to avoid the parts from being scratched.
- Check to be sure that you have all parts and hardware.
- Remove all wrapping materials, including staples & packing straps before you start to assemble.
- Do not tighten all screws / bolts until all completely assembled.
- Keep all hardware parts out of reach of children.

Each Barstool

PARTS LIST

NO	DESCRIPTION	QTY
1	BACK REST	1 PC
2	BOX FRAME	1 PC
3	FRONT LEG (Left & Right)	2 PCS
4	SIDE STRETCHER (Left & Right)	2 PCS
5	FRONT STRETCHER with marking	1 PC
6	WOODEN SEAT	1 PC

HARDWARE LIST

NO	DESCRIPTION	QTY
A	JCBC SCREW M6 x 80mm	4 PCS
B	JCBC SCREW M6 x 70mm	4 PCS
C	JCBC SCREW M6 x 40mm	3 PCS
D	SPRING WASHER Ø8 x 15mm	11 PCS
E	FLAT WASHER Ø8 x 22mm	11 PCS
F	ALLEN KEY M4	1 PC
G	CSK SCREW M4 x 38mm	10 PCS

Step : 1

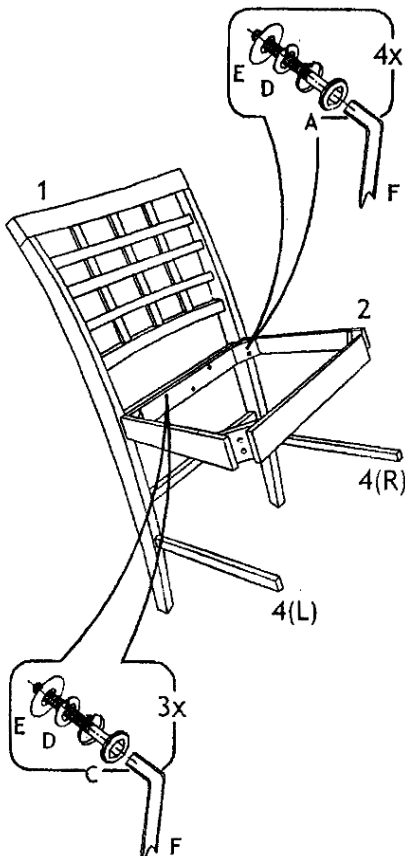

Step : 2

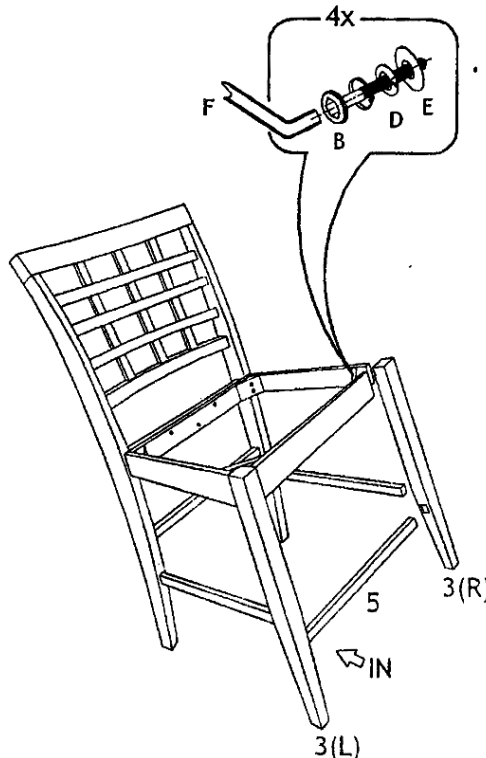

Step : 3

